

Well Probe

Mechanically Activated Device for Dry Run Protection in Applications with LORENTZ Solar Pump Systems

The switch can be used to detect the water level within a well. When the water level in the well dropped below the level of the well probe, the LORENTZ Controller will stop the pump and indicates Source Low LED.

ORDER INFORMATION

- **Item no.:** 19-000000 **product name:** Well probe sensor

FEATURES

- Reliable dry run protection
- Simple to install
- Trouble free operation
- Corrosion-free
- Splicing kit included

TECHNICAL DATA

- Max. operating temperature 55 °C
- Enclosure class: IP68
Submersion depth: max 50 m
- Cable length: 1.5m
- Wire size: 2x 0.75mm² or AWG 19, waterproofed
- Mounted in vertical position
- Meets the requirements for CE

DIMENSION/WEIGHT

- Packaging dimensions: 260 x 170 x 40 mm
10.3 x 6.7 x 1.6 in
- Total weight: 0.1 kg / 0.2 lbs

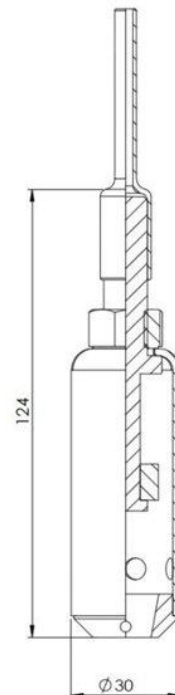

Water Sensor

Device for Dry Run Protection in Applications with LORENTZ Solar Surface Pump Systems

The device can be used to detect the water level in the suction side of the pipeline. When the two electrodes run dry, the LORENTZ Controller will stop the pump and indicates Source Low LED.

ORDER INFORMATION

- **Item no.:** 19-000001 **product name:** Water sensor, pipe inst.
- **Item no.:** 19-000002 **product name:** SS adapter
- **Item no.:** 19-000003 **product name:** Steel adapter

Pipeline adapter must be ordered separately
(available as steel or stainless steel version)



FEATURES

- Reliable dry run protection
- Trouble free operation

TECHNICAL DATA

- Max. operating temperature 70 °C
- Enclosure class: IP54
- Cable length: 4 m
- Wire size: 2x 1.0mm² or AWG 17, waterproofed
- Mounted in vertical position
- Meets the requirements for CE

DIMENSION/WEIGHT

- Packaging dimensions: 180 x 180 x 80 mm
7.1 x 7.1 x 3.1in
- Total weight: 3.5kg / 7.7lbs

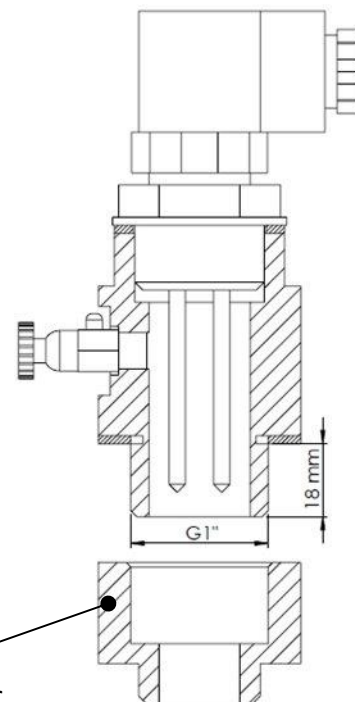

Float Switch

Mechanically Activated Device for Water Level Detection in Applications with LORENTZ Solar Pump Systems

The switch can be used to detect the water level within a tank. When the water level in the tank reaches the maximum, the LORENTZ Controller will stop the pump and indicates Tank Full LED.

ORDER INFORMATION

- **Item no.:** 19-000030 **product name:** Float Switch

FEATURES

- **N.O.** (normally open) and **N.C.** (normally closed) function
- Reliable water level detection
- Simple to install
- Trouble free operation
- Not sensitive to rotation
- Corrosion-free



TECHNICAL DATA

- Operating temperature: -10°C to 55°C
- Storage temperature: : -10°C to 55°C
- Enclosure class: IP68
- Cable length: 3m, waterproof
- Wire size: 3x 1.0mm² or AWG 18
- Meets the requirements for CE

DIMENSION/WEIGHT

- Packaging dimensions: 230 x 160 x 55 mm
9.1 x 6.3 x 2.2 in
- Total weight: 0.8 kg / 1.8 lbs

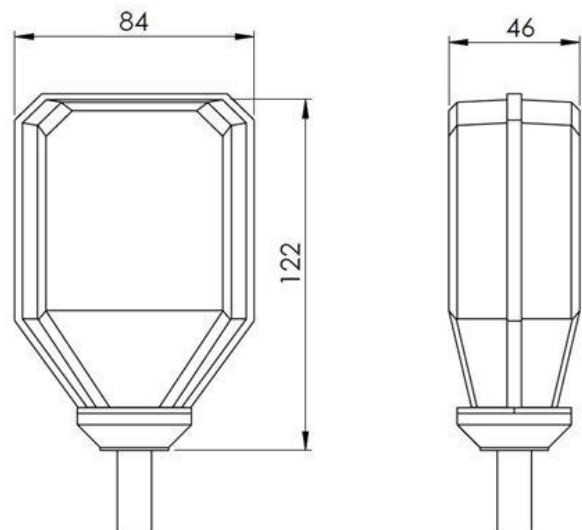

Pressure Switch

Device for Water Pressure Detection in Applications with LORENTZ Solar Pump Systems

The switch can be used to detect the water level within a tank. When the water level in the tank reaches the maximum, the pressure will increase and the LORENTZ Controller will stop the pump and indicates Tank Full LED.

ORDER INFORMATION

- **Item no.:** 19-000310 **product name:** Pressure Switch 1-5bar

FEATURES

- Reliable water pressure detection
- Simple to install
- Trouble free operation
- Corrosion-free

TECHNICAL DATA

- Pressure range between 1 and 5 bar
- 2x cable gland \varnothing 5-9mm
- G $\frac{1}{4}$ " pipe thread
- Meets the requirements for CE



DIMENSION/WEIGHT

- Packaging dimensions: 130 x 105 x 65 mm
5.1 x 4.2 x 2.6 in
- Total weight: 0.5 kg / 1 lbs

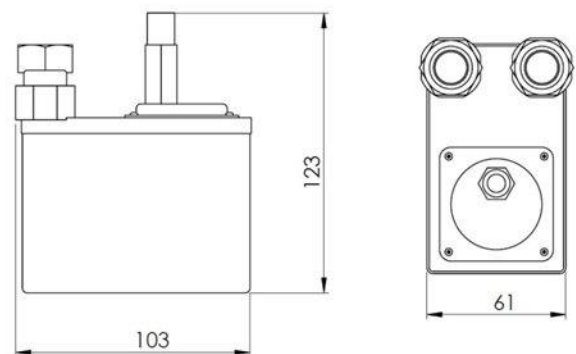

Liquid Level Sensor

Sensor for measuring the level of liquid in a well or tank

USE / PURPOSE

The range of liquid level sensors use pressure to measure the liquid level in a well or tank. The sensors can be used for collection of long term liquid level monitoring and also for pump control in applications where a well probe cannot be used. The liquid level sensor must be used with a compatible LORENTZ Controller (see requirements).

FEATURES

- Gauge pressure sensor, pressure measurement relative to atmosphere
- For measuring levels of liquid in a well or tank
- Accurate, robust sensor
- For use with LORENTZ PumpScanner and pumpMANAGER

REQUIREMENTS

- LORENTZ PS2 controller , LORENTZ PSk2 controller or PS Controller equipped with a licensed PS DataModule
- The cable contains a capillary tube to balance the sensor against atmospheric changes. The sensor must be ordered with the required cable length for the application as it cannot be spliced. Further cable lengths are available on demand, please contact LORENTZ.



TECHNICAL DATA

- Sensor type: 2 wire gauge sensor
- Enclosure class: IP68
- Sensor housing: stainless steel
- Connects to LORENTZ PS DataModule
- Oil resistant cable with capillary tube
- Overpressure: 2x full scale
- Output signal :4-20mA output
- Voltage : 12-28VDC
- Application temp.: -10 to 80°C
14 to 176°F
- Accuracy class :0.5% FS
- Meets the requirements for CE

DIMENSION/WEIGHT

- Packing dimensions:
19-005040: 350 x 350 x 100 mm / 13.8 x 13.8 x 3.9 in
19-005050: 350 x 350 x 100 mm / 13.8 x 13.8 x 3.9 in
19-005080: 350 x 350 x 100 mm / 13.8 x 13.8 x 3.9 in
- Weight:
19-005040: 4 kg / 8.8 lbs
19-005050: 5 kg / 11.0 lbs
19-005080: 7 kg / 15.4 lbs

ORDER INFORMATION

Item #	Product	Pressure range	Cable length
19-005040	Liquid Level Sensor, 0-10m/30ft, 30m/100ft Cable	0-100 kPa 0 to 10 m / 0 to 30 ft 0 to 1 bar / 0 to 14.5 psi	30 m / 100 ft *
19-005050	Liquid Level Sensor, 0-20m/60ft, 40m/130ft Cable	0-200 kPa 0 to 20 m / 0 to 60 ft 0 to 2 bar / 0 to 29 psi	40 m / 130 ft *
19-005080	Liquid Level Sensor, 0-50m/160ft, 60m/200ft Cable	0-500 kPa 0 to 50 m / 0 to 160 ft 0 to 5 bar / 0 to 72.5 psi	60 m / 200 ft *

*Further cable length are available on demand. Please contact LORENTZ.

BERNT LORENTZ GmbH & Co. KG
Kroegerskoppel , 24558 Henstedt-Ulzburg, Germany
Tel +49 (0)4193 7548-0, Fax -29, www.lorentz.de

Sun. Water. Life.

Liquid Pressure Sensor

Sensor for measuring the pressure of liquid in a pipe or vessel

USE / PURPOSE

The sensors are commonly used to measure the pressure in the delivery pipeline or in a vessel. The pressure signal is used with a suitable LORENTZ pump controller to measure pressure and for pressure switching or constant pressure applications. The liquid pressure sensor must be used with a compatible LORENTZ Controller (see requirements).

FEATURES

- Gauge pressure sensor, pressure measurement relative to atmosphere
- For measuring pressure in a pipe or vessel
- Accurate, robust sensor
- For use with LORENTZ PumpScanner and pumpMANAGER

REQUIREMENTS

- LORENTZ PS2 controller , LORENTZ PSk2 controller or PS Controller equipped with a licensed PS DataModule
- Care must be taken to position the sensor without turbulent water to ensure accurate measurement
- G1/4" or G1/2" female threaded filling / air vent hole is required to mount the sensor

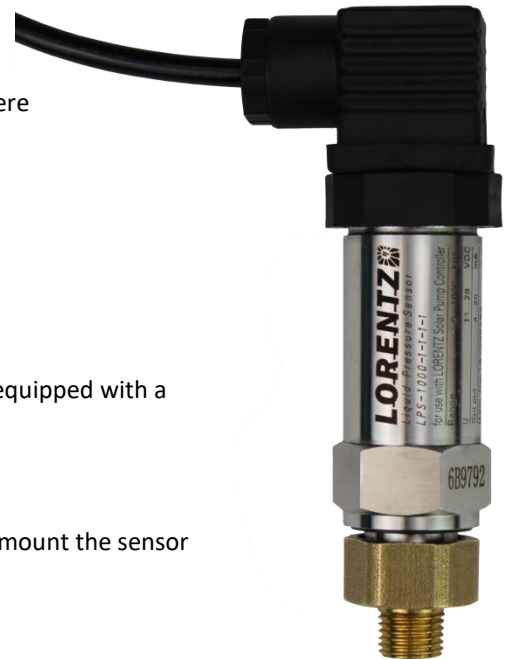

TECHNICAL DATA

- Sensor type: 2 wire gauge sensor
- Enclosure class: IP65
- Sensor housing : stainless steel
- Connects to LORENTZ PS DataModule
- 1m (3 ft) cable length
- Overpressure: 1.5x full scale
- Output signal : 4-20 mA
- Voltage : 11-28 VDC
- Application temp.: -30 to 80°C
-22 to 176°F
- Accuracy class : 0.5% full scale
- Thread type: G1/2" male (G1/4" with adapter)
- Meets the requirements for CS

ORDER INFORMATION

Item #	Product	Pressure range
19-004450	Liquid Pressure Sensor, LPS-500	0-500 kPa 0 to 50 m / 0 to 160 ft 0 to 5 bar / 0 to 72.5 psi
19-004460	Liquid Pressure Sensor, LPS-1000	0-1000 kPa 0 to 100 m / 0 to 330 ft 0 to 10 bar / 0 to 145 psi

DIMENSION/WEIGHT

- Packing dimensions: 190 x 180 x 80 mm
7.5 x 7.1 x 3.2 in
- Weight: 0.6 kg / 1.3 lbs

Water Meter

Device to measure the water flow rate

ORDER INFORMATION

- **Item no.:** 19-002160 **product name:** Water Meter, WP-DN40, 0.1cbm/p
- **Item no.:** 19-002170 **product name:** Water Meter, WP-DN65, 0.1cbm/p
- **Item no.:** 19-002180 **product name:** Water Meter, WP-DN80, 0.1cbm/p
- **Item no.:** 19-002190 **product name:** Water Meter, WP-DN100, 0.1cbm/p
- **Item no.:** 19-002200 **product name:** Water Meter, WP-DN125, 0.1cbm/p
- **Item no.:** 19-002210 **product name:** Water Meter, WP-DN150, 1cbm/p
- **Item no.:** 19-002202 **product name:** Water Meter, WP-DN200, 1cbm/p

FEATURES

- Dry dial register ensures clear reading
- Low pressure loss, long working life
- Easy to install
- **Only for use in combination with DataModule:**
 - The water meter is equipped with a reed switch assembly which can be connected to the DataModule



TECHNICAL DATA

- Water temperature: max. 40°C
- Water pressure: max. 16 bar
- Meets the requirements for CE

Nominal Diameter	DN	40	65	80	100	125	150	200
Max. flow rate [m ³ /h]	Q _{max}	20	50	80	120	200	300	500
Nominal flow rate [m ³ /h]	Q _n	10	25	40	60	100	150	250
Transition flow rate [m ³ /h]	Q _t	3.0	5.0	8.0	12	20	30	50
Minimum flow rate [m ³ /h]	Q _{min}	0.7	0.75	1.2	1.8	3.0	4.5	7.5

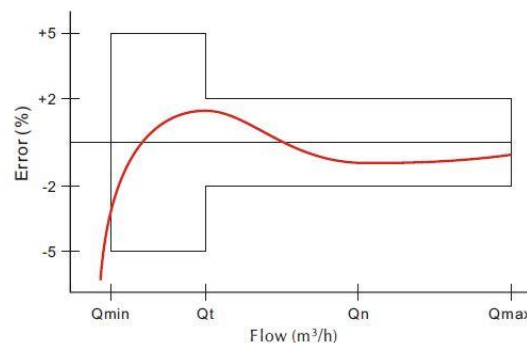

BERNT LORENTZ GmbH & Co. KG
 Siebenstuecken 24, 24558 Henstedt-Ulzburg, Germany
 Tel +49 (0)4193 8806-700, www.lorentz.de

Sun. Water. Life.

All specifications and information are given with good intent, errors are possible and products may be subject to change without notice. Pictures may differ from actual products depending on local market requirements and regulations.

DIMENSION/WEIGHT

Nominal Diameter	DN	40	65	80	100	125	150	200
Length [mm]	L	260	200	225	250	250	300	350
Height [mm]	H	225	242	252	262	275	325	355
Working height [mm]	H1	303	313	323	333	346	396	426
Height [mm]	G	360	360	360	360	360	420	420
Outside diameter [mm]	D	150	185	200	220	250	285	340
Circle diameter [mm]	D1	110	145	160	180	210	240	295
Connecting bolt quantity		4xM16	4xM16	8xM16	8xM16	8xM16	8xM20	12xM20
Weight [kg]		12	13	16	18	20	42	74

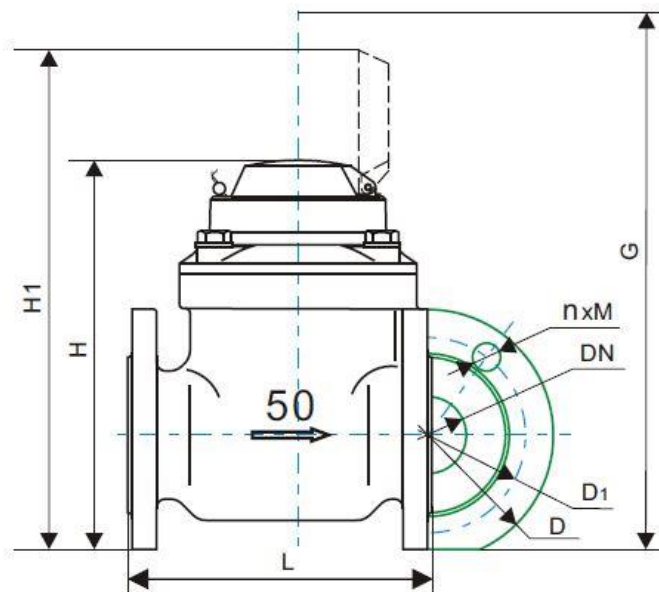

SunSwitch

Automatic Solar Level Switching Device

The SunSwitch can be used for any application where you need to switch depending on the solar intensity. It is an autonomous working unit that supplies itself with power from the PV-module on its rear side.

ORDER INFORMATION

- **Item no.:** 19-000050 **product name:** SUN SWITCH Light-Sensor

FEATURES

- Trouble free operation
- Pump will only run when minimum flow rates or pressure levels can be achieved which are required by certain applications
- Reduced wear on the pump and motor since the pump only starts when it will continue to run

TECHNICAL DATA

- Contact rating:
 - Max. voltage 250 VAC / 220 VDC
 - Max. current 2A
 - Max. power 60 W / 62.5 VA
- Enclosure class: IP54
- Cable length: 4 m
- Wire size: 3x 1.0mm² or AWG 18, waterproofed
- Mounted close to the solar array
- Manual with further informations is available in PartnerNet
- Meets the requirements for CE

DIMENSION/WEIGHT

- Packaging dimensions: 230 x 115 x 90 mm
9.1 x 4.5 x 3.5 in
- Total weight: 1.2 kg / 0.6 lbs



Surge Protector

Device to Protect LORENTZ Pump Accessories from Voltage Spikes

ORDER INFORMATION

- **Item no.:** 19-000280 **product name:** Surge Protector

FEATURES

- Reliable surge protection for all LORENTZ pump accessories
- Can be installed inside the PS Controller

TECHNICAL DATA

- Max. voltage: 14 VDC
- Max current 8/20 μ s: 500 A
- Enclosure class: IP65
- Ambient temperature: max. 50°C
- Wire size: 2x 1.5mm² or AWG 16
- Meets the requirements for CE



DIMENSION/WEIGHT

- Packing dimensions: 70 x 45 x 20 mm
 2.8 x 1.8 x 0.8 in
- Total weight 0.1 kg / 0.2 lbs

PV Disconnect 440-40-1

Box with DC Disconnect Switch and optional lightning surge protection

ORDER INFORMATION

- **Item no.:** 19-000137 **product name:** PV Disconnect 440-40-1
- **Item no.:** 19-002120 **product name:** MNSPD-115
- **Item no.:** 19-002130 **product name:** MNSPD-300
- **Item no.:** 19-002140 **product name:** MNSPD-600

Lightning surge protectors must be ordered separately

FEATURES

- Designed for PS150 – PS4000
- For professional installation of pumping systems

TECHNICAL DATA

- DC rated disconnect switch enclosed
- Enclosure class IP 54
- Meets the requirements for CE

PV Disconnect 440-20-1	
Max. voltage	440 V DC
Max. current	40 A
String cable size	4 - 10 mm ²
Output cable size	4 - 10 mm ²

DIMENSION/WEIGHT [mm]

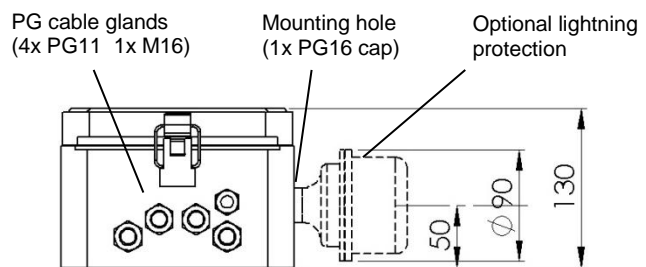
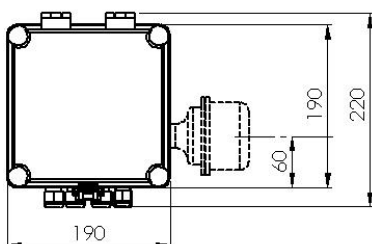

Net. Weight: 1,4kg (+0,35kg)



Optional lightning surge protector

- Connects through an existing mounting hole in the PV connect housing
- Proper grounding of the device is mandatory to achieve protection

Controller	MidNite surge protector
PS150 – PS200	MNSPD115
PS600 – PS1800	MNSPD300
PS4000	MNSPD600

PV Disconnect 440-40-6

Connection box with DC Disconnect Switch and optional lightning surge protection

ORDER INFORMATION

- **Item no.:** 19-000136 **product name:** PV Disconnect 440-40-6
- **Item no.:** 19-002120 **product name:** MNSPD-115
- **Item no.:** 19-002130 **product name:** MNSPD-300
- **Item no.:** 19-002140 **product name:** MNSPD-600

Lightning surge protectors must be ordered separately

FEATURES

- Designed for PS150 – PS4000
- For professional installation of pumping systems

TECHNICAL DATA

- Wiring up to 6 PV-strings in parallel
- DC rated disconnect switch enclosed
- Enclosure class IP 54
- Meets the requirements for CE

PV Disconnect 440-40-6

Max. voltage	440 V DC
Max. current per string	10 A
Max. total current	40 A
Max. no. of strings	6
String cable size	2,5 - 4mm ²
Output cable size	4 - 10mm ²

DIMENSION/WEIGHT [mm]

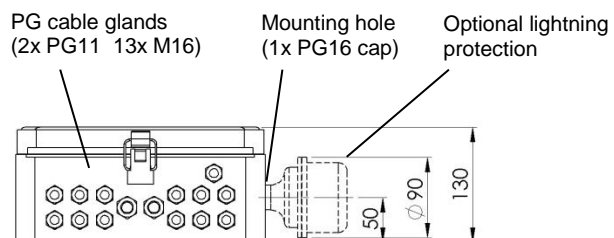
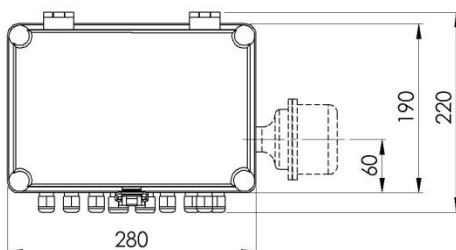

Net. Weight: 2,15kg (+0,35kg)



Optional lightning surge protector

- Connects through an existing mounting hole in the PV connect housing
- Proper grounding of the device is mandatory to achieve protection

Controller

MidNite surge protector

PS150 – PS200	MNSPD115
PS600 – PS1800	MNSPD300
PS4000	MNSPD600

PP600H AC PowerPack

AC/DC Converter to Supply PS600, PS1200HR and specific PS1800HR Pump Systems with Backup Power from a Generator or Mains Supply

ORDER INFORMATION

- Item no.: 19-001040 product name: Power Pack 600H, UL
- Item no.: 19-001060 product name: Power Pack 600H SS, UL (SS stainless steel enclosure)

TECHNICAL DATA

- AC input: 120V or 240V ($\pm 15\%$), selectable, 47 to 63Hz
- AC input current: 6.2A (120V) or 3.1A (240V)
- PV input voltage: V_{mp} : 130V DC, depending on pump controller max. voltages
- PV max open circuit voltage: 200V DC depending on pump controller max. voltages
- DC output: 120V DC (no load), 700W
- Overload protection: internal fuse, 15A
- Enclosure: steel, gasket-sealed, indoor-use, hinged front cover with key-lock
- Must be protected from direct mid-day sun
- Enclosure class: IP22
- Ambient temperature: max. 45°C
- All wires must be #14 AWG (2.5 mm²) or larger
- Manual with further information is available in PartnerNet
- Meets the requirements for CE



Electrical Safety



DIMENSION/WEIGHT

- Packaging dimensions: 450 x 300 x 140 mm
17.7 x 11.8 x 5.5 in
- Total weight: 16 kg / 35 lbs

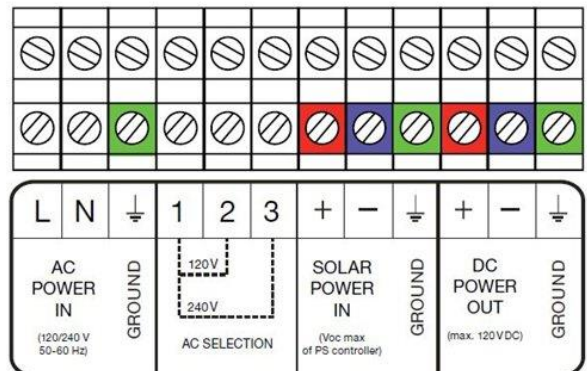

BERNT LORENTZ GmbH & Co. KG
Siebenstuecken 24, 24558 Henstedt-Ulzburg, Germany
Tel +49 (0)4193 8806-700, www.lorentz.de

Sun. Water. Life.

All specifications and information are given with good intent, errors are possible and products may be subject to change without notice. Pictures may differ from actual products depending on local market requirements and regulations.

PM Accessory bracket

Kit for mounting LORENTZ PS Controller / PV-Disconnect to the Pole Mount PM-1-X

USE / PURPOSE

The PM Accessory bracket is designed for use with the LORENTZ POLE MOUNT-1-X.

The Set allows an easy and flexible mounting of LORENTZ PS Controllers and PV-Disconnect on the Pole of the LORENTZ PM-1-X.



ORDER INFORMATION

Part	Item No.	PM-1-1	PM-1-2	PM-1-3	PM-1-4	PM-1-5	PM-1-6
PM Accessory bracket 2.5-1	19-004220	x	x				
PM Accessory bracket 4-1	19-004210			x	x	x	x

FEATURES

- Simple and cost effective mounting possibility for LORENTZ Controller and PV-Disconnect
- Designed for LORENTZ Pole Mount 1-X

TECHNICAL DATA

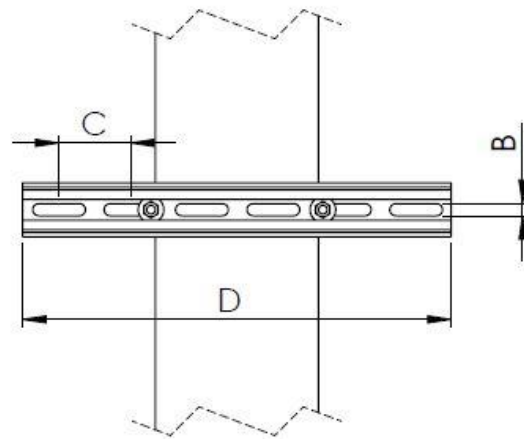
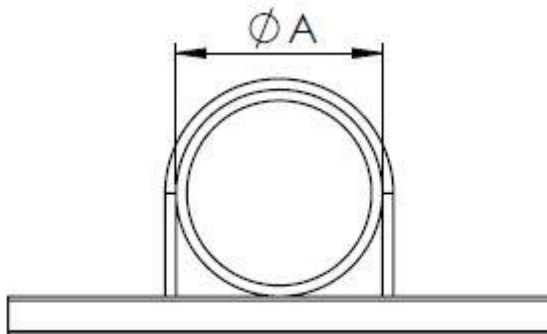

	A	B	C	D	Weight	Item no.
PM-1- 1/2	70 -73 mm 2.5 " SCH40	8.5 x 37 mm 0.33 x 1.4 "	50 mm 2 "	300 mm 11.8 "	0.35 kg 0.77 lbs.	19-004220
PM-1- 3/4/5/6	114.3 mm 4 " SCH40				0.4 kg 0.88 lbs.	19-004210

Packing dimensions

305x170x25 mm
12x7x1 inch

BERNT LORENTZ GmbH & Co. KG
Siebenstuecken 24, 24558 Henstedt-Ulzburg, Germany
Tel +49 (0)4193 8806-700, www.lorentz.de

Sun. Water. Life.

Sun Sensor

Irradiation measurement module and software

The LORENTZ Sun Sensor module and software allow the PS2 controller to accurately estimate irradiation levels and control the pump based on this.

The Sun Sensor function can be configured to offer the pump mechanical protection from repeated stop starts. The Sun Sensor function can also be configured to switch external devices via the PS2 output terminals.

Each module is tested and specially calibrated for use with the PS2 system. The Module also includes a software license to use the features which is accessed via the item serial number.

This Sun Sensor module is included with any PS2-1800 or PS2-4000 controller.

For PS controllers (non PS2) refer to the SunSwitch Datasheet.

ORDER INFORMATION

- **Item no.:** 19-005030
- **Product name:** Sun Sensor module

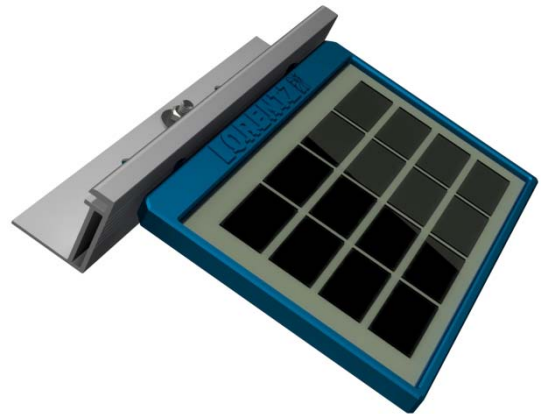

TECHNICAL DATA

- Open circuit voltage $V_{oc} = 10.2 \text{ V}$
- Short circuit current $I_{sc} = 0.19 \text{ A}$
- Wire size: 3x 1.0mm² or AWG 18, waterproofed
- Mount close to the solar array
- PS2 manual with further information is available in PartnerNet
- Meets the requirements for CE

DIMENSION/WEIGHT

- Packaging dimensions: 180 x 205 x 60 mm
7.08 x 8.07 x 2.36 in
- Total weight: 0.6 kg / 1.33 lbs