

# Water Sensor

## Device for Dry Run Protection in Applications with LORENTZ Solar Surface Pump Systems

The device can be used to detect the water level in the suction side of the pipeline. When the two electrodes run dry, the LORENTZ Controller will stop the pump and indicates Source Low LED.

### ORDER INFORMATION

- **Item no.:** 19-000001    **product name:** Water sensor, pipe inst.
- **Item no.:** 19-000002    **product name:** SS adapter
- **Item no.:** 19-000003    **product name:** Steel adapter

Pipeline adapter must be ordered separately  
(available as steel or stainless steel version)



### FEATURES

- Reliable dry run protection
- Trouble free operation

### TECHNICAL DATA

- Max. operating temperature 70 °C
- Enclosure class: IP54
- Cable length: 4 m
- Wire size: 2x 1.0mm<sup>2</sup> or AWG 17, waterproofed
- Mounted in vertical position
- Meets the requirements for CE

### DIMENSION/WEIGHT

- Packaging dimensions: 180 x 180 x 80 mm  
7.1 x 7.1 x 3.1in
- Total weight: 3.5kg / 7.7lbs

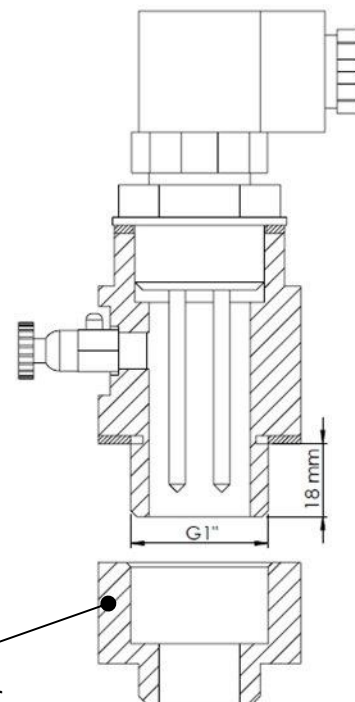

pipeline adapter